

PART 1 - GENERAL**1.01 SUMMARY:**

- .01 Provide special glassfiber reinforced cement (GRC) shapes in accordance with the requirements of the contract documents.
- .02 The installing contractor shall be responsible for verifying that all required blocking is provided and installed in the correct locations for GRC component's proper installation.

1.02 WORK INCLUDED

- .01 Supply of GRC units.
- .02 Erection/installation.
- .03 Joint treatment
- .04 Supply and installation of backup supports, shimming labor and materials, etc.

1.03 RELATED WORK SPECIFIED ELSEWHERE:

- .01 Framing and support systems.
- .02 Caulking.
- .03 Finishes. The paint manufacturer shall recommend a breathable primer and paint, suitable for cement surfaces.

1.04 QUALITY ASSURANCE:

- .01 Materials and work shall conform to the latest edition of reference specifications specified herein and to applicable codes and requirements of local authorities having jurisdiction.

1.05 QUALIFICATION:

- .01 The manufacturer of glassfiber reinforced cement work shall submit evidence of satisfactory projects completed over the last 10 years.
- .02 The installer of the work specified herein shall be approved by the manufacturer of the specified material.
- .03 The installer of the work, with more than 5 years experience in the installation of GRC units, shall carry out the installation efficiently and co-operate fully with other trades.

1.06 CERTIFICATION/REFERENCES:

- .01 Submit manufacturer's product data, including copies of fire test reports.
- .02 Except as otherwise additionally indicated on the drawings or specified herein, the standards referred to below, shall apply to work under this section.

.1	ASTM C 473	Nail Pull Resistance
.2	ASTM C 473	Humidified Deflection
.3	ASTM C 947	Elastic Limits
.4	ASTM D 256	Impact Resistance
.5	ASTM D 638	Ultimate Tensile Strength
.6	ASTM D 638	Young's Modulus
.7	ASTM D 696	Coefficient of Linear Thermal Expansion
.8	ASTM D 790	Flexural Strength
.9	ASTM D 790	Flexural Modulus
.10	ASTM D 2583	Barcol Hardness
.11	ASTM E 84	Flame Spread Index,
.12	ASTM E 84	Smoke Developed Index

1.07 DESCRIPTION OF WORK:

- .01 This specification is intended to outline the general requirements of the DecoForm (GRC) units as they pertain to the overall design of the project. The manufacturer's recommendations shall not govern the work in this section.
- .02 The installing contractor shall perform all work in this section, including installation, caulking, filling and patching and will assume responsibility for coordinating installation with associated trades.
- .03 GRC is a decorative non-load bearing material and as such the manufacturer cannot be held responsible for structural, load, or seismic considerations.

1.08 DESIGN CRITERIA:

- .01 Unless stated on DecoForm's drawings, fabrication tolerances are as indicated below.

.1	Dimensional - all directions (0' - 10')	± 1/8" (3.2mm)
.2	Dimensional - all directions (11' - 20')	± 3/16" (4.8mm)
.3	Straightness along an edge or surface	± 1/8"/linear ft.
.4	All reveals, setbacks or returns	5° draft
.5	All corners	1/16" - 1/8" radius

1.09 SAMPLES:

- .01 Submit duplicate min. 6" x 6" GRC samples.

1.10 SHOP DRAWINGS:

- .01 Submit for approval, shop drawings of units which show sections, details, joint treatment and the relation of the GRC units to adjoining components.

1.11 SCHEDULING:

- .01 Special scheduling for site coordination must be specified at time of bidding.

1.12 DELIVERY, STORAGE AND HANDLING:

- .01 Units shall be handled and transported in a manner so as not to create damage or excessive stresses.
- .02 GRC units shall be stored level on a clean dry surface in an area protected from weather, moisture and damage. The units shall not be stacked or leaned unless instructed otherwise by the manufacturer.

1.13 WARRANTY:

- .01 The manufacturer warrants that the delivered material supplied will conform to sample and to specifications and will be free from defects in workmanship or material under normal use and conditions for a period of one year from date of shipment. Should defects, attributable to the manufacturer, appear within one year of the date of shipment, the manufacturer has the option of replacing or repairing the defective material.
- .02 Limitations: The aforementioned general warranty is exclusive. All other warranties whether expressed or implied or arising by operation of law, usage of trade, course of dealings or otherwise, are excluded. The only warranties are those expressed above. The manufacturer shall not be liable for any penalty or for any loss or damages associated with the removal or installation of its product or claims of third parties against the Purchaser.

PART 2 - PRODUCTS**2.01 MANUFACTURER:**

DecoForm Inc.
49 Sheffield Street
Toronto, Ontario
CANADA M6M 3E5
Phone: (416) 745-4970
Toll-free 1-877-DECOFORM
FAX: (416) 745-6636
E-mail: sales@decoform.com
Website: www.decoform.com

2.02 MATERIALS:

- .01 GRC units shall be prefabricated with glassfiber reinforced cement.
- .02 Units will be suitably reinforced with additional materials as required.
- .03 GRC units are supplied primer ready. Finishing is specified elsewhere and shall be applied after the GRC units are installed.
- .04 Exposed fasteners shall be stainless steel. All other fastening or attachment devices shall be appropriately plated or galvanized.
- .05 Where cast-in texture is specified, the texture shall be approved at time of sample submission.
- .06 Related product sections include:
 - .1 Columns Master Spec. 03 49 13
 - .2 Trim Master Spec. 03 49 43
 - .3 Cementitious Panels Master Spec. 07 44 53

2.03 PHYSICAL PROPERTIES:

- .01 Glass content 5 - 6% by weight,
- .02 Weight (depending on reinforcing) 2.9 lbs/sq.ft.
- .03 Shell Thickness 3/8" nominal (1/4" min.)
- .04 Flame Spread Index (ASTM E 84) 0 (Class 1) (Class A)
- .05 Smoke Developed Index (ASTM E 84) 0 (Class 1) (Class A)
- .06 Flexural Strength (ASTM D 790) 4,650 psi (32.1 MPa)
- .07 Flexural Modulus (ASTM D 790) 1.43×10^6 (9,860 MPa)
- .08 Elastic Limit (ASTM C 947) 981 psi (6.70 MPa) avg.
- .09 Ultimate Tensile Strength (ASTM D 638) 1,480 psi (10.2 MPa)
- .10 Impact Resistance (ASTM D 256) 7.83 ft.lb./in (mean value)
- .11 Barcol Hardness (ASTM D 2583) 81 Avg.
- .12 Coef. of Thermal Expansion (ASTM D 696) 5.50×10^{-6} in/in °F/ 9.95×10^{-6} mm/mm
- .13 Nail Pull (wood embedment) (ASTM C 473) 466 lbf. Avg.
- .14 Nail Pull (metal embedment) (ASTM A 473) 139 lbf. Avg.
- .15 Humidified Deflection (ASTM C 473) 0.2 mm. mean deflection
- .16 Compressive Strength (ASTM C 472) 10,364 psi.
- .17 Young's Modulus (ASTM D 638) 1.48×10^6

PART 3 - EXECUTION**3.01 EXAMINATION:**

- .01 Prior to the manufacture of components, the installer shall check all pertinent site dimensions and conditions against the manufacturer's drawings and relay discrepancies to the manufacturer for inclusion in the drawings.
- .02 Prior to installation, the installer shall compare job site dimensions and conditions against the Architect's drawings and shall report any discrepancies to the General Contractor and the Architect. Work shall not proceed until discrepancies are corrected.
- .03 Prior to installation, the installer shall examine pertinent job-site conditions to insure proper arrangement and fit of the work. Start of work implies acceptance of job-site condition.
- .04 All surfaces or framing structures shall be plumb and true as required.

3.02 ERECTION:

- .01 Install work as indicated on drawings, as specified herein and in accordance with approved shop drawings and manufacturer's recommendations.
- .02 Provide all support framing/reinforcing/support brackets required for work of this section and to ensure solid and secure installation.
- .03 Provide temporary supports to maintain position as units are being installed.
- .04 Fasten units with screws through the face of the GRC unit(s), or from the rear.
- .05 Adequate control and/or expansion joints shall be employed.
- .06 Pre-drill fastener holes in GRC components. Clean fastener holes to remove dirt and oil.
- .07 Attach GRC components to framing and substrate with steel drill screws. Do not use pneumatic staple guns. Countersink screw heads below adjoining finished surface.
- .08 Fasten not less than 5/16" from edge or end.
- .09 Cover screw heads with joint compound to produce, smooth, flush and level surfaces.
- .10 GRC units shall be handled with care and lifted with appropriate equipment.
- .11 GRC units shall be installed true and plumb, shimmed where necessary.
- .12 Caulk joints where required with a one-compound elastomeric low modulus urethane sealant equivalent to Sonolastic Ultra. Control joints shall be provided where required as specified by Architect. Color of caulk to be selected by Architect.
- .13 Expansion joints shall be installed as per Architect's recommendation.
- .14 Anchors and fasteners: Type 304 stainless steel where exposed; hot dip galvanized steel where unexposed.

3.03 PATCHING AND CLEANING:

- .01 Repair any defects found after the work of all trades has been completed, regardless of how, or by whom, the damage was caused. Patching shall match the original work. Use Auto Body filler or a polymer modified cementitious product with migrating corrosion inhibitors equivalent to Sika Top to repair any defects and areas requiring patching. Select the correct product by application.
- .02 Patch all countersunk fasteners and damages to match unit's texture, finished flush with face of unit.
- .03 Soiled units may be cleaned using detergent and water.

3.04 FINISHING:

- .01 All DecoForm GRC requires site prime and paint. Use only breathable primers and paints/coatings equivalent to Sherwin-Williams Loxon A-100 breathable primers and paints).

Decoform**Material Safety Data Sheet**

Section 1
Product and Company Information

PRODUCT NAME: **Glassfiber Reinforced Cement (GRC)**

PRODUCT USE: Architectural Decorations

MANUFACTURER: DecoForm Inc.
49 Sheffield Street
Toronto, ON
Canada M6M 3E5
Tel.: 416-745-4970
Fax: 416-745-6636

Section 2
Composition Information on Ingredients

CHEMICAL NAMES

	WT%	TLV (mg/m ³)	PEL (mg/m ³)	CAS NUMBER
Glassfiber Mat	6	10	15	65997-17-3
Plaster of Paris	21	10	15	26499-65-0
Portland Cement	42	10	15	65997-15-1
Sand	31	0.05 (R)	0.1 (R)	14808-60-7
Acrylic Polymer				107-21-1

Section 3
Hazard Identification

EMERGENCY OVERVIEW

This product is not expected to produce any unusual hazards during normal use. Exposure to high dust levels may irritate the skin, eyes, nose, throat or upper respiratory tract. Portland Cement is a nuisance dust.

Section 4 First Aid Measures

FIRST AID PROCEDURES

Eyes: Flush thoroughly with water. If irritation persists, consult a physician.

Skin: Wash with mild soap and water. Commercially available hand lotion may be used to treat dry skin areas. If irritation persists consult a physician.

Inhalation: Remove to fresh air. Other measures are usually not necessary, however if conditions warrant consult a physician.

Ingestion: This product is not intended to be ingested or eaten. If gastric disturbance occurs, call a physician.

Section 5 Fire Fighting Measures

General Fire Hazards:	Not expected to burn
Unusual Fire & Explosion Hazards:	None
Hazardous Combustion Products:	
Plaster of Paris:	Above 1450° C – decomposes to calcium oxide (CaO) and sulfur dioxide (SO ₂)
Glass mat:	Primary decomposition products include hydrocarbons and water. Due to the low polyester content, the material should self extinguish when the heat source is removed.

Section 6 Accidental Release Measures

CONTAINMENT:

No special precautions.

CLEAN-UP:

Use normal clean up procedures.

DISPOSAL:

Follow local, state, provincial and federal regulations when disposing industrial waste. Keep spills and cleaning runoff out of municipal sewers and open bodies of water.

Section 7
Handling and Storage

HANDLING:

Avoid dust contact with eyes. Wear appropriate eye protection against dust. Avoid breathing dust. Wear appropriate respiratory protection against dust in poorly ventilated areas. Use good safety and industrial hygiene practices.

STORAGE:

Store in a cool, dry, ventilated area away from sources of heat, moisture and incompatibilities.

Dew point conditions or other conditions causing the presence of liquid will harden this material during storage.

Section 8

The information contained herein is believed to be true and accurate but is not warranted To be, whether originating with DecoForm or not. Customers are advised to confirm that information is current, applicable and suitable to the circumstances.

DecoForm Inc. will not be liable for claims relating to any party's use of or reliance on information and data contained herein regardless of whether it is claimed that the information and data are inaccurate, incomplete or otherwise misleading.

Preparation Date: September 1, 2007 Issue: 3 Replaces Issue: 2

MANUFACTURER CERTIFICATION FOR LEED CREDIT

I, the manufacturer of _____ as specified in Master Specification Section Number _____

Do herein certify that:

1. The materials were manufactured at our plant in Toronto, Ontario, Canada.
2. The materials were extracted or harvested at the United States Gypsum Company (USG) in Norman, OK.
3. The manufactured product contains 0% Post Consumer recycled materials and 5% Pre Consumer recycled materials.
4. Product data submitted under separate cover.

DecoForm contributes to greener construction management by:

1. Using a single mould to **produce many** parts and **retooling** allows moulds to be **reused** for more than one project.
2. **Minimizing construction waste** with our pre-molded easy to install products.
3. Our glassfiber reinforced gypsum and cement (similar to concrete) can be **reused** as filler in many construction products.

Manufacturer: DecoForm Inc.

Certification by: _____

Date: _____

Name: Wally Omran

Title: President



(1) Locate center of structural column and scribe a line on both sides which extend further than the base to be installed later.



(2) Use a plumb bob or laser to transfer center line onto ceiling.

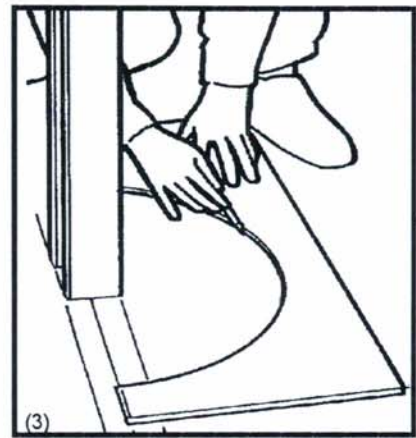

(3) Cut "base" and "capital" plywood templates using paper outline supplied by DecoForm. Place "base" template on floor, center on structural column and trace entire outline. With "capital" template, duplicate this procedure on the ceiling tracing the rectangular profile only.



(7) Scribe line on structural column at height "Y" as measured in step (6).

Cut and instal top cross brace at height "Y" to insure Dia. "X" minus 1/4".

Repeat @ 180 degrees on column.

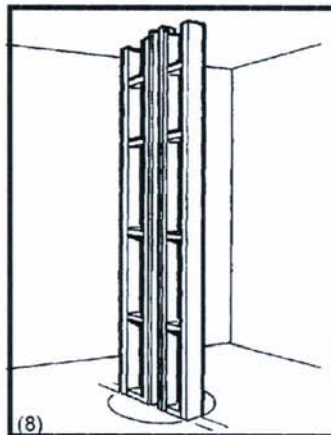

(8) Measure and cut cross-bracing to appropriate lengths and instal @ 24" centers.

Using straight edge on outer, vertical frame, insure that there is no bowing.

Skeleton should be solid and plumb.

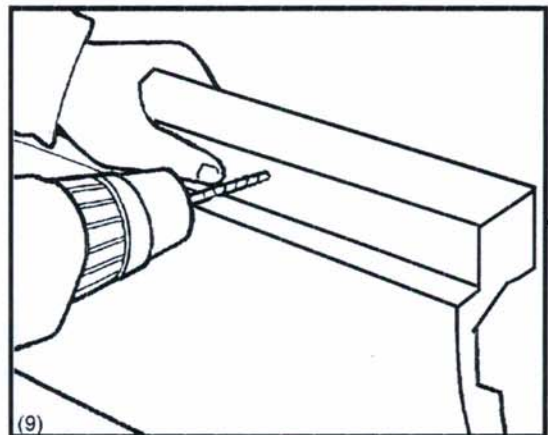

(9) On the column cover half with the larger vertical flange ("AS"), drill and countersink hole 6" from lower end of column cover half and at 16" centers thereafter. Repeat on other column cover half starting at 5" from lower end but drill holes in center of flange as well as into the overlap joint at capital. Refer to drawing "A" (lower right of opposite page).

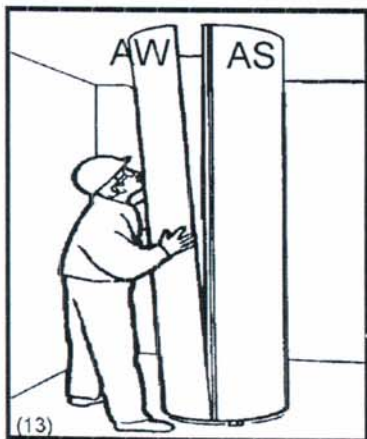

(13) Locate mating column cover half and position around flange on other column half so as to insure proper fit.

Shim at base to match first column cover half Shim joint with 1/4" spacer.

Refer to Detail "A" on opposite side of page.

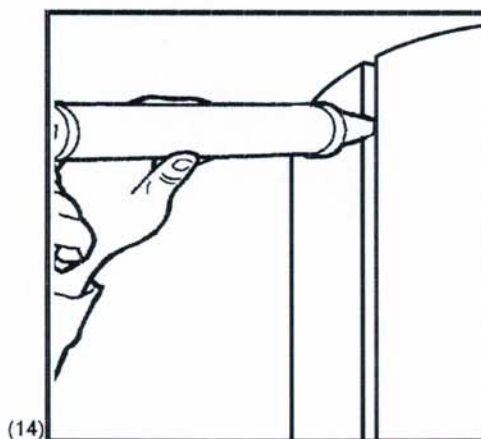

(14) Using a low modulus, paintable caulking, caulk all seams including horizontal reveals at floor and ceiling. Ensure weeping hole at bottom of column. Patch and sand screw holes with joint compound.

Prime & paint using breathable products.

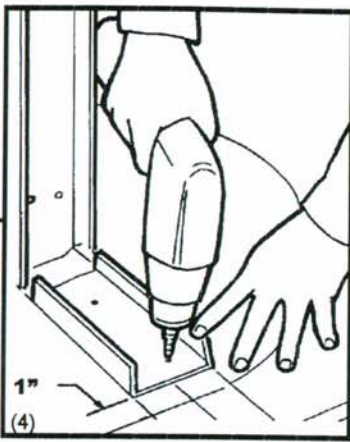

(4) Fasten framing to structural column on center-line and plumb.

Fasten base blocking on center-line 1" back from circle scribed on floor.

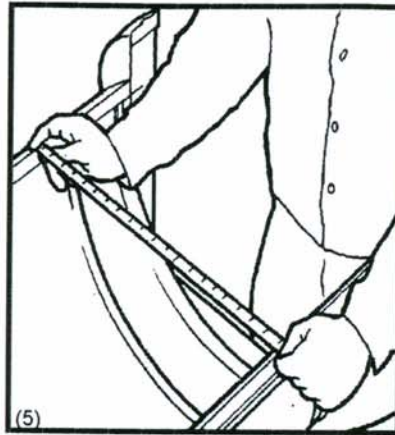

(5) Locate column cover half which has the larger, indented vertical flange.

Measure the inner diameter between flanges (at the capital). (Dia. "X").

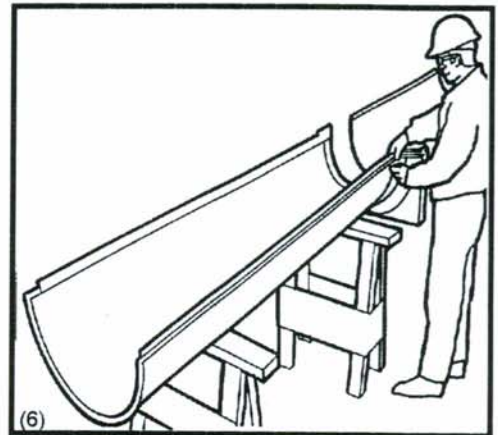

(6) Measure length of column cover half from lower end to the point at which the diameter was measured in step #5. (Dim. "Y").



(10) Locate column cover half as identified by the larger, indented vertical flange and position over scribed circular line on floor.

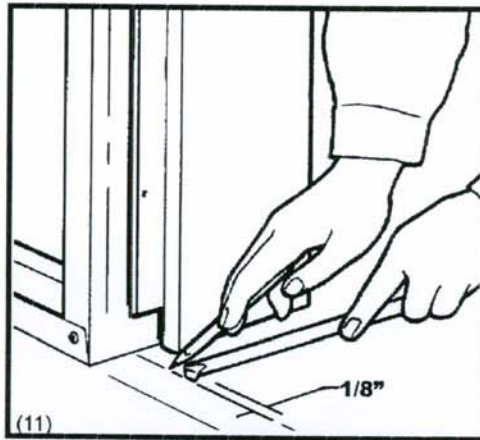

(11) Place the column cover half with the outside diameter, 1/8" back of scribed center line.

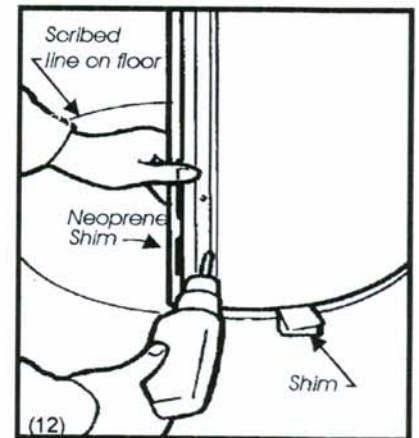

(12) Shim bottom of column cover half until top is 1/8" from ceiling or passes through ceiling. Use neoprene shim between column cover and framing to insure O.D. of column cover is held. Plumb and fasten through previously drilled holes.

